

## Issue of building permit certificate, building completion certificate and water & electricity connection application work flow

The purpose of this document is to layout to projects' owners and consultants' offices the work flow of applications submitted to issue building permit, building completion certificate, water & electricity and sewage connections.

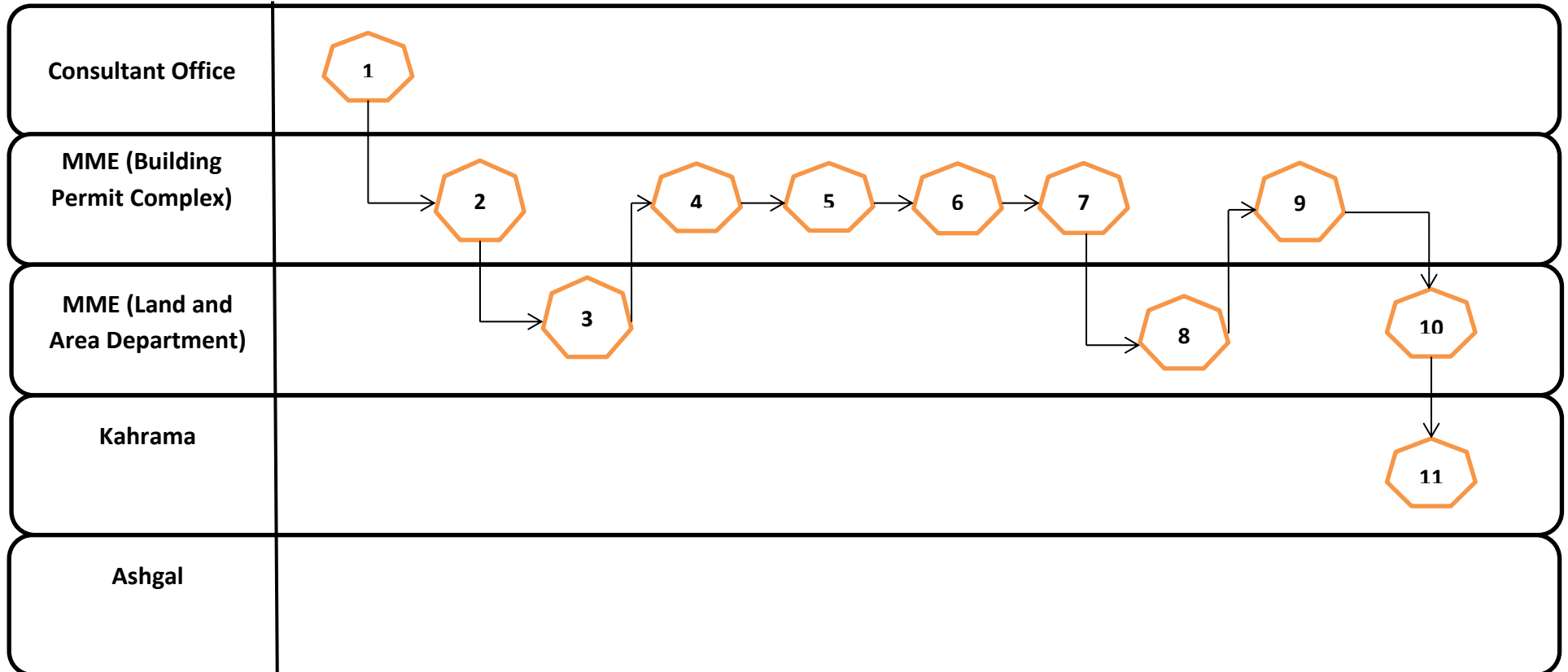

The following are procedures to be done in order to obtain a building permit certificate, a building completion certificate and water & electricity and sewage connection:

1

Hire Consultant to make design drawings for the project

2

\*Obtaining clearance from the building permit complex to indicate the land's utilization, right to use and allowed number of stories

3

Submit survey report to make sure project is constructed within land's boundary

4

Submit architectural drawings in Design Control 1 (DC1) stage 1 for review and approval

5

Submit Civil Defence life safety drawings, Kahrama electrical & water and Ashgal road plans in Design Control 1 (DC1) stage 2 for review and approval

6

Submit undertaking letters from supervise consultant and project contractor to abide by Qatar construction standards

7

Submit building services design drawing in Design Control 2 (DC2) for review and approval (Civil Defence and Kahrama Services' drawings)

8

Submit survey report to make sure project is constructed within land's boundary (After construction of the is completed)

9

Conduct building inspection to obtain building completion certificate

10

\*\* Obtain water and electricity connection

11

\*\* Obtain sewage connection

- \*Procedure of obtaining clearance from the building permit complex to indicate the land's utilization, right to use and number of stories allowed is not mandatory for some projects (Warehouses, Private villas, and governmental projects)
- \*\*Applications that could be submitted in parallel
- Estimate of construction cost to conduct fees calculation is 2400 QR for every square meter of buildup area

**Procedure #**      **Key Performance Indicator for Every Procedure**      **Cost for every procedure in Qatar Ryails**

1	1 Day	-
2	1 Day	-
3	1 Day*	500
4	5 Days	-
5	14 Days	0.15% of the total cost of the project**
6	0.5 Day	-
7	14 Days	-
8	1 Day	500

9	5 Days	1000
10	5 Days	-
11	5 Days**	-

**Total Number of days is 47.5**

- \*Procedure of obtaining clearance from the building permit complex to indicate the land utilization, right to use and number of stories allowed is not mandatory for some projects (Warehouses, Private villas, and governmental projects)
- \*\*Applications that could be submitted in parallel
- Estimate of construction cost to conduct fees calculation is 2400 QR for every square meter of buildup area